

Keep this rotor instruction manual and the centrifuge manual in the file.

---

## Continuous Flow Rotors for High-Speed Refrigerated Centrifuge (CR30NX)

---

Before using the rotor, please carefully read this instruction manual and the centrifuge instruction manual for its efficient operation and for your safety.



Keep this instruction manual for your reference and refer to it as required.







## Safety Reminder

- Centrifuge rotors rotating at high speed have considerable potential for damage to personal properties if used improperly.  
For safe and proper use of this rotor, carefully read the centrifuge instruction manual and this rotor instruction manual before use and observe the instructions.

 **WARNING :** and  **CAUTION :** notes are used to call your attention in this manual to prevent personal injury or damage to the rotor and the centrifuge.

These notes are defined as follows.

 **WARNING:** indicates a potentially hazardous situation which, if not avoided, could result in personal severe injury or possible death.

 **CAUTION:** indicates a hazardous situation which, if not avoided, could result in personal injury or severe damage to the instrument.

### **WARNING**

- Never use any material capable of producing flammable or explosive vapors.
- Your centrifuge and rotor are not designed to confine any sample particles dispersed due to leakage. Therefore, when using toxic or radioactive samples or pathogenic or infectious blood samples, make sure to prepare necessary safety measures at your own responsibility.
- Never exceed the maximum speed of the rotor (mentioned on the surface of the rotor). Always reduce rotor speed as instructed in this manual when rotor speed is limited due to sample density.
- Check the attached chemical resistance chart, and do not use any sample inapplicable to the rotor.
- If the centrifuge, rotor, or an accessory is contaminated by samples that toxic or radioactive, or blood samples that pathogenic or infectious, be sure to decontaminate the item according to good laboratory procedures and methods.
- If there is a possibility that the centrifuge, rotor, or an accessory is contaminated by samples that might impair human health (for example, samples that are toxic or radioactive, or blood samples that are pathogenic or infectious), it is your responsibility to sterilize or decontaminate the centrifuge, rotor, or the accessory properly before requesting repairs from an authorized sales or service representative.
- It is your responsibility to sterilize and/or decontaminate the centrifuge, rotor, or parts properly before returning them to an authorized sales or service representative.

### **CAUTION**

- Clean the inside of the drive hole (crown hole) of the rotor and the surface of the drive shaft (crown) of the centrifuge once a month. If the drive hole or the drive shaft is stained or any foreign matter is adhered, the rotor may be improperly installed and come off during operation.
- When the rotor speed exceeds 3,000rpm, it can be filled with samples.
- Inspect and maintain the rotor after use. If abnormality is observed, do not use it. Contact an authorized sales or service representative.

# Table of Contents

---

	Page
Safety Reminder	(i)
1. Introduction	1
2. Specifications	1
2.1 Specifications of rotors	1
2.2 Structure	1
2.3 Applicable centrifuge and configuration of combinations	2
2.4 Allowable rotor speeds	2
2.5 Sample limitations	3
2.6 Structures when a rotor and a seal unit are combined	3
3. Assembly	5
3.1 Assembling of rotor section of seal type continuous flow rotor	5
3.2 Assembling of seal section of seal type continuous flow rotor	6
3.3 Assembling of batch rotor	8
4. Preparation of centrifuge	10
4.1 Preparation of stainless steel ring	10
4.2 Positioning of stainless steel ring	10
5. Preparation of spinning	11
5.1 Seal type continuous flow rotor	11
6. Determination of flow rate	15
7. Operation	17
7.1 Seal type continuous flow rotor	17
7.2 Batch rotor	19
8. How to take out sediment	19
9. Maintenance	19
9.1 Maintenance of rotor	19
9.2 Sterilizing rotor	20
9.3 Inspecting rotor	20
10. Separation characteristic table	21
10.1 R18C2	21
10.2 R10C2	23
11. Decontamination	24
12. Rotor retirement	24
13. Parts List	25
13.1 List of parts provided with continuous flow rotor	25
13.2 Components of seal unit (sold separately) for series of continuous flow rotors	26
13.3 Components of batch unit (sold separately) for series of continuous flow rotors	28

# 1. Introduction

We thank you very much for purchasing the continuous flow rotor series for High-speed refrigerated centrifuge.

This continuous flow rotor series has large relative centrifugal force and capacity, and is excellent in continuous processability. It can be easily assembled and disassembled, thus making it a product easy to handle.

According to its application, it is used as seal type continuous flow rotor or batch rotor. This instruction manual describes necessary matters on operation and maintenance in order to use this rotor series correctly and sufficiently exhibiting its performance.

Be sure to read through this instruction manual before proceeding to operation.

## 2. Specifications

### 2.1 Specification of rotors

Table 2-1. Specification of the continuous flow rotors

Item \ Rotor	R18C2	R10C2
Max. speed (rpm)	18,000	10,000
Max. RCF ( $\times g$ )	35,100	14,290
Total capacity (mL)	1,000	3,200
Pellet capacity (mL)	500	2,300

### 2.2 Structure

With the continuous flow rotor series, different combinations of rotor and unit give seal type continuous flow rotor and batch rotor.

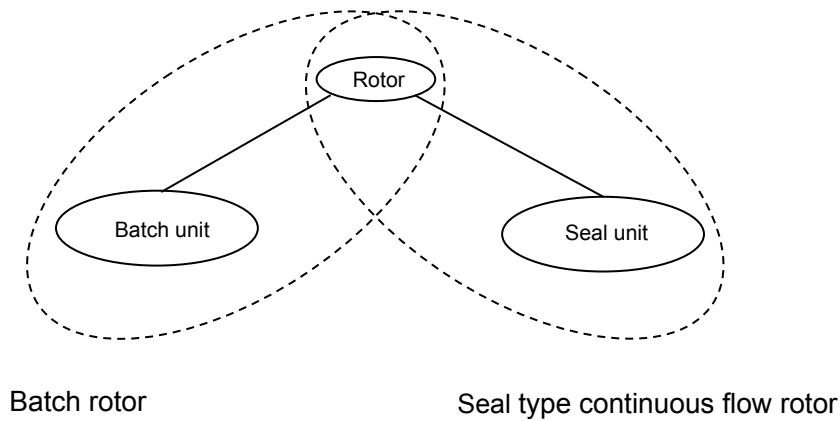

## 2.3 Applicable centrifuge and configuration of combinations

Applicable centrifuge: CR30NX

**⚠ CAUTION:**  
The R18C2/R10C2 rotor is exclusively for the CR30NX centrifuge. It can not be used with any other centrifuge.

Table 2-2 shows the combination of rotors for each unit.

Table 2-2. Combination of rotors for each unit

Unit \ Rotor	R18C2	R10C2
	Seal unit	R18C2 Seal unit ass'y (P/N S205974A)
Batch unit	R18C2 Batch ass'y (P/N S311483A)	R10C2 Batch ass'y (P/N S311495A)

## 2.4 Allowable rotor speeds

**⚠ WARNING:**  
The rotor should never be used at any speed higher than the maximum speed mentioned on the rotor. Depending upon the density of samples in use, however, the rotor may not be used at its maximum speed. It must be lowered to following allowable speed under some conditions.  
**DO NOT** exceed this allowable speed.

### ● Allowable speed for sample density

**⚠ WARNING:**  
Never run the rotor at its maximum speed when using a sample with an average density more than 1.2g/mL.

To centrifuge a sample with an average density more than 1.2g/mL, reduce to the allowable speed calculate by the following equation.

$$\text{Allowable speed (rpm)} = \text{Maximum speed of rotor (rpm)} \times \sqrt{\frac{1.2(\text{g/mL})}{\text{Average density of sample (g/mL)}}}$$

\*The maximum allowable speed in this equation is that printed on rotor.

## 2.5 Sample limitations

The rotor has excellent corrosion resistance because of its anodic oxidation. However, do not use the following samples as they will corrode the rotor:  
strong acid, strong alkaline solution, heavy metal salt solution, i.e. compounds of iron, copper, lead, silver or mercury

### ⚠ WARNING:

- These rotors and the centrifuge are not explosion-proof. Never use explosive or flammable samples.
- For safety, there are limits on the use of bio-samples which require bio-isolation, such as pathogenic germs and DNA recombination, as well as RI substance in centrifuges. Perform strict safety controls when separating samples containing these substances.
- Check the attached chemical resistance chart, and do not use any sample inapplicable to the rotor. Using such a sample could corrode or deteriorate it.

### ⚠ CAUTION:

- Use a sample having a pH between 5 and 9. Check the attached chemical resistance chart, and do not use any sample inapplicable to the rotor. Otherwise the rotor may be corroded.
- When using the batch rotor, cool the sample and the rotor less of the set temperature, and then tighten the rotor cover. Failure to do so can cause the rotor cover not to be removed, because the internal pressure of the rotor might be less of the external pressure.

## 2.6 Structures when a rotor and a seal unit are combined

Fig.2-1 to 2-3 shows the Structures when a rotor and each unit are combined.

	R18C2	R10C2
Seal unit	Fig.2-1	Fig.2-2
Batch unit	Fig.2-3	

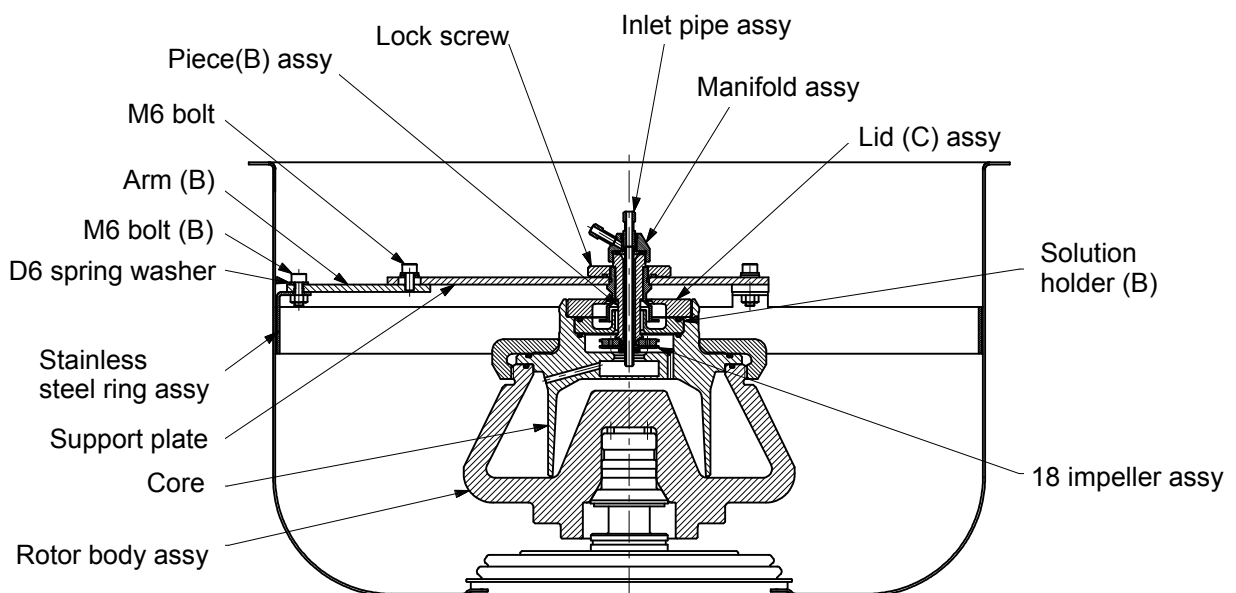

Fig.2-1 Combination of R18C2 Rotor and Seal Unit



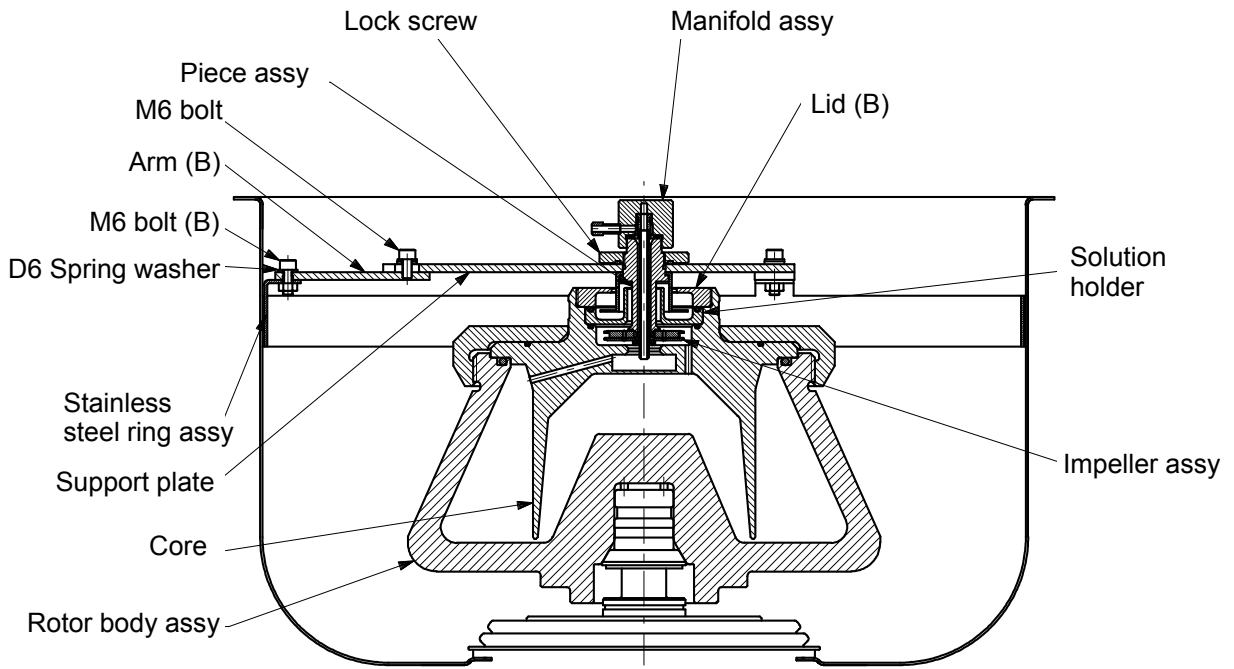

Fig.2-2 Combination of R10C2 Rotor and Seal Unit

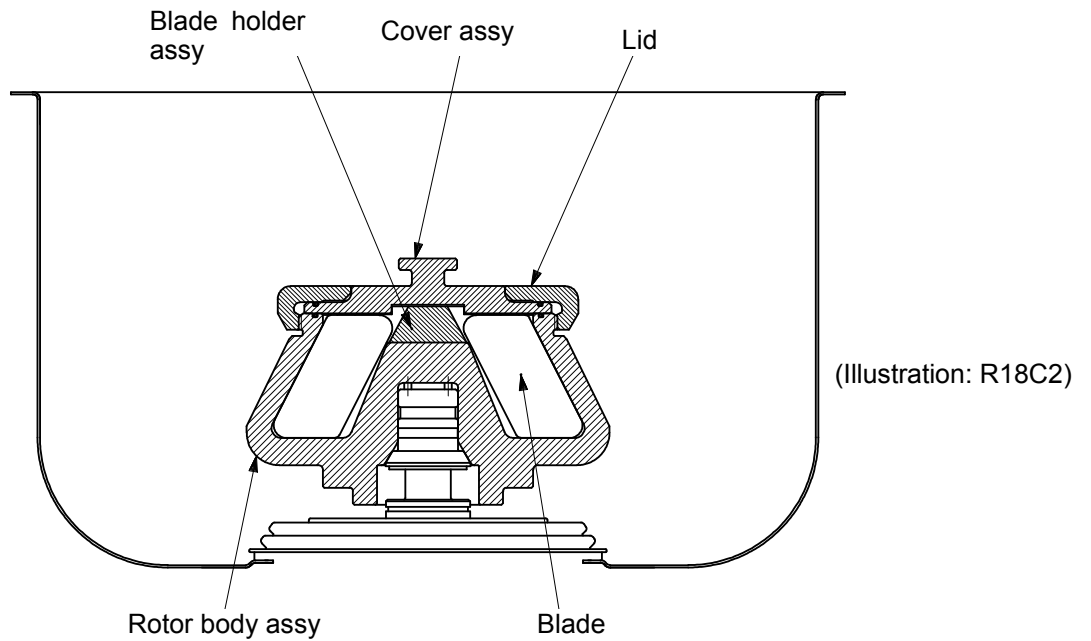

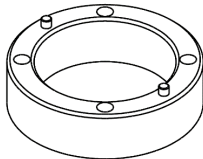
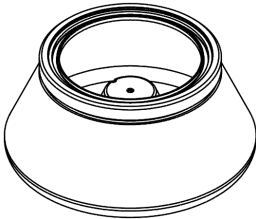
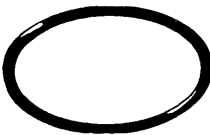
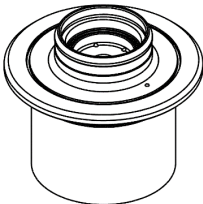

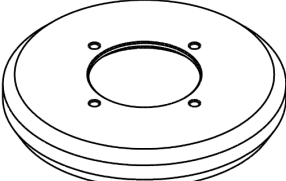

Fig.2-3 Combination of Rotor and Batch Unit

### 3. Assembly

The assembly procedure differs according to the particular combination of the rotor and unit. Carry out assemble in the procedure illustrated below.

**⚠ CAUTION:**  
 Since O-ring and seal packing which are used in the rotor or the connecting portion of the seal section will come into contact with sample, always rinse them before use. When these parts are replaced, some residue generated when rubber was formed Rinse them away before use.

#### 3.1 Assembling of rotor section of seal type continuous flow rotor

Assembly order	Components	Procedure
1	Base assy 	Install base assy on desk, bench or the like with wood screw.
2	Rotor body assy 	Put rotor body on base assy (align rotor body pin hole with base assy pin). Coat rotor body threads with lubricant for screw.
3	Rotor packing (O-ring) 	Install rotor packing thinly coated with silicone grease in rotor body groove.
4	Seal unit core 	Put core in rotor body assy.
5	R18C2 Rotor packing (O-ring)  R10C2 O-ring 	Install O-ring thinly coated with silicone grease in core groove.
6	Lid 	Screw lid to rotor body assy after applying lubricant for screw.
7	Handle 	Tighten lid firmly by handle (unit it stops).
<p><b>⚠ CAUTION:</b>                  Firmly tighten the lid to completely seal the sample in rotor: Insufficient tightening could cause the sample to leak at high-speed rotation.</p>		

Continue to perform section 3.2 when assembling a seal type continuous flow rotor.

### 3.2 Assembling seal section of seal type continuous flow rotor

**Components of Seal Type Continuous Flow Rotor**

	Name	Rotor type	
		R18C2	R10C2
①	O-ring (Model)	84520302 (P8)	84522301 (P7)
②	Manifold assy	481360A	S413935A
③	Inlet pipe assy	341543A	S413934A
④	O-ring (Model)	84520303 (P14)	
⑤	Lock screw assy	S403915B	
⑥	Lid	S408101	481352
⑦	Piece assy	S304946B	341541B
⑧	O-ring (Model)	84520301 (P6)	
⑨	O-ring (Model)	84520311 (G65)	
⑩	Solution holder	S408100	481350
⑪	Impeller assy	S408121B	481375B
⑫	O-ring (Model)	84520311 (G65)	
⑬	O-ring (Model)	84520312 (G135)	4836572
⑭	Core	S102782	S102784
⑮	Rotor		

Note that the parts in the seal sections are different for R18C2 and R10C2.



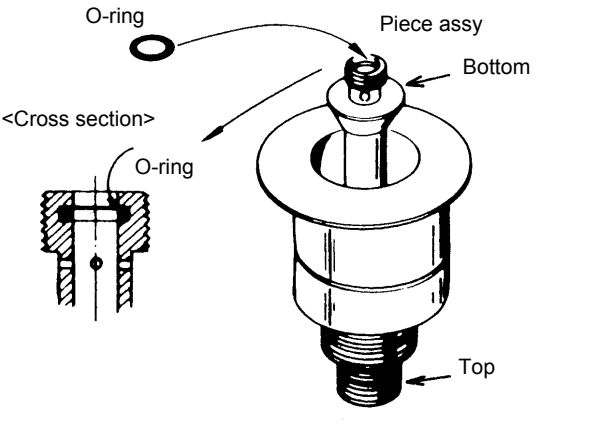
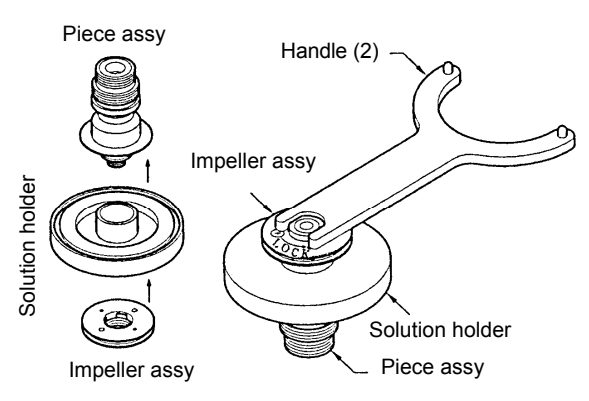
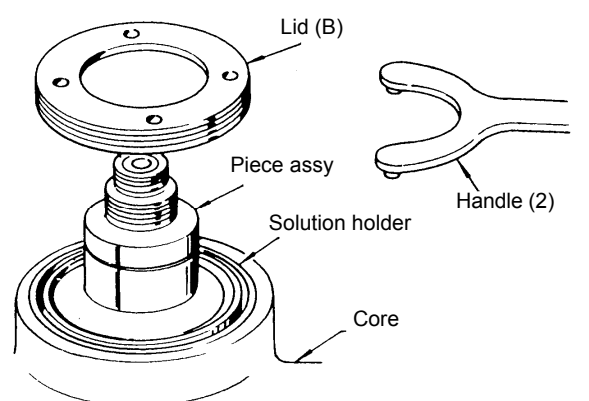
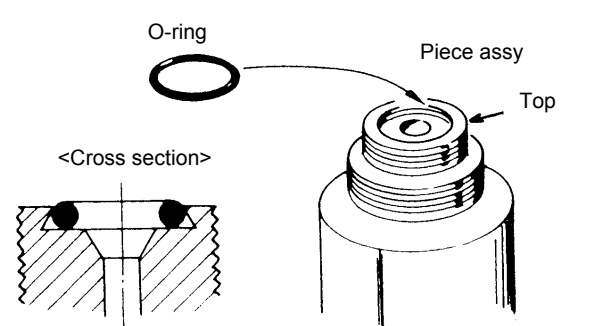

Assembly order	Components	Procedure
1		Install O-ring (G65) thinly coated with silicone grease in O-ring groove on core. (may be after assembly in 3.1)
2		Install O-ring (G65) thinly coated with silicone grease in O-ring groove on solution holder.

Assembly order	Components	Procedure
3		<p>Install O-ring (P6) thinly coated with silicone grease in O-ring groove (inside) on piece assy.</p>
4		<p>Combine the solution holder with the piece assembly, place the impeller assembly with the printed characters facing up as shown in the figure on left, and then screw it into the piece assembly. Use the wrench side of handle (2) to screw it in. Note that the directions of rotation to tighten the different impeller assemblies are different. Tighten the impeller in the direction of the arrow on its</p>
5		<p>Insert the piece assembly, solution holder and impeller assembly that have been assembled in step 4 into the core. Screw in the lid, and then use handle (2) to tighten it. Perform the above procedure with the rotor left mounted on base assembly after assembly in section 3.1.</p>
6		<p>Fit the O-ring (P14) coated thinly with silicone grease in the reverse tapered portion in the top edge of piece assembly.</p>

When the above assembly is complete, proceed with "4. Preparation of centrifuge".

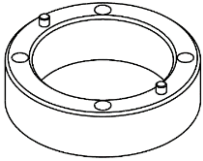
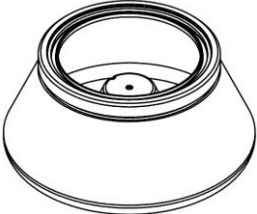
### 3.3 Assembling of batch rotor

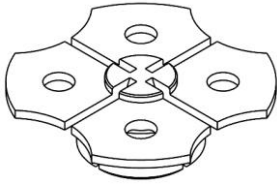
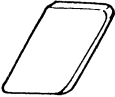
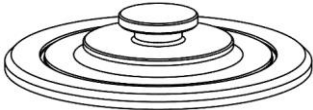
Refer to "13.3 Components of batch unit for series of continuous flow rotors" for the components.

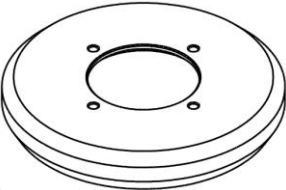
Assembly order	Components	Procedure
1	Base assy 	Install base assy on desk, bench or the like wood screws.
2	Rotor body assy 	Put rotor body on base assy (align rotor body pin hole with base assy pin). Coat rotor body thread with lubricant for screw.
3	Rotor packing (O-ring) 	Install rotor packing thinly coated with silicone grease in rotor body groove.
4	Injection of sample	Inject sample a minimum 90% of rotor capacity.
5	Blade holder assy 	Put blade holder assy in rotor. Notches at rotor center are engaged with pins of blade holder assy, thus preventing from dislocating.
6	Blade 	Put 4 blades in blade holder assy groove.
7	Cover assy 	Put cover in.
8	R18C2 Rotor packing (O-ring)  R10C2 O-ring 	Install O-ring thinly coated with silicone grease in cover assy groove.
9	Lid 	Screw lid to rotor body assy after applying lubricant for screw.

Assembly order	Components	Procedure
10	Handle 	Tighten lid firmly by handle (until it stops.).
<p>⚠ CAUTION: Firmly tighten the lid to completely seal the sample in rotor. Insufficient tightening could cause the sample to leak at high-speed rotation.</p>		

## 4. Preparation of centrifuge (unnecessary in case of batch rotor)

### 4.1 Preparation of stainless steel ring

Prepare it as illustrated in Fig. 4-1.

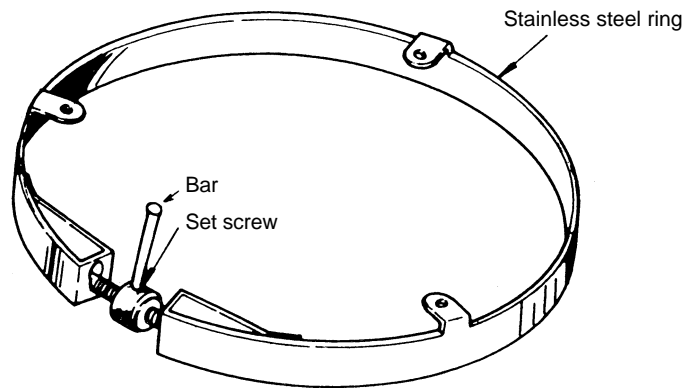

Fig. 4-1

### 4.2 Positioning stainless steel ring

As depicted in Fig. 4-2, put in the rotor chamber of the refrigerated centrifuge the ring with its setscrew loosened. Fasten the ring in the rotor chamber by tightening the setscrew with bar to match the height H in Table 4-1 according to the particular rotor it.

**⚠ CAUTION:**

Remove the ring from the chamber of the refrigerated centrifuge when using the rotors other than the continuous flow rotors. Otherwise, the buckets of swing rotors may touch the ring when the rotor is rotating, and it may result in damage to both buckets of the rotor and the centrifuge.

Table 4-1 Height H (mm)

	Seal unit
R18C2	200 ~ 210
R10C2	235 ~ 254

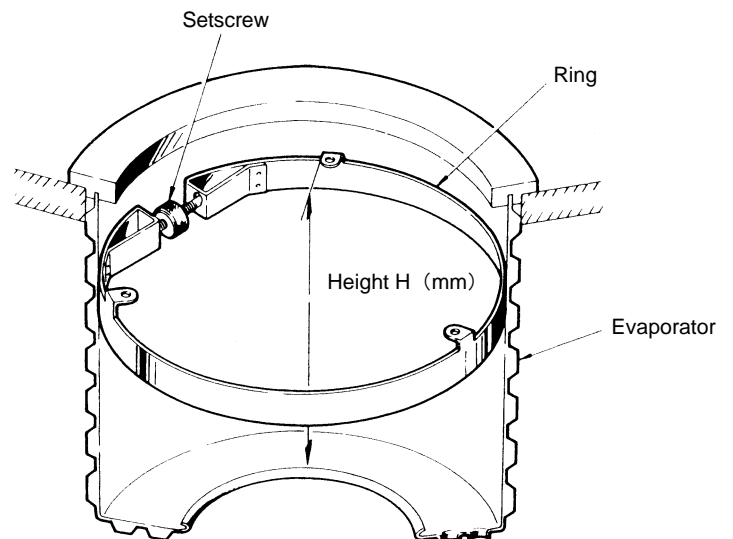
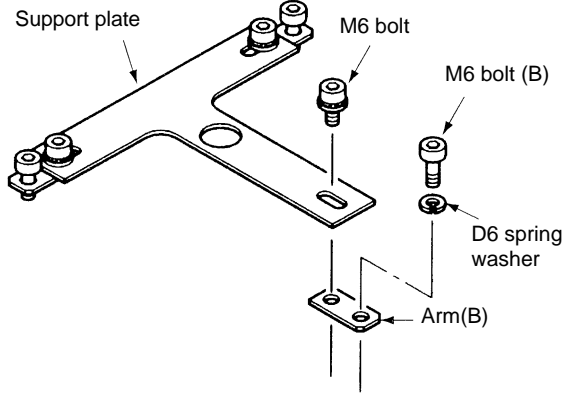
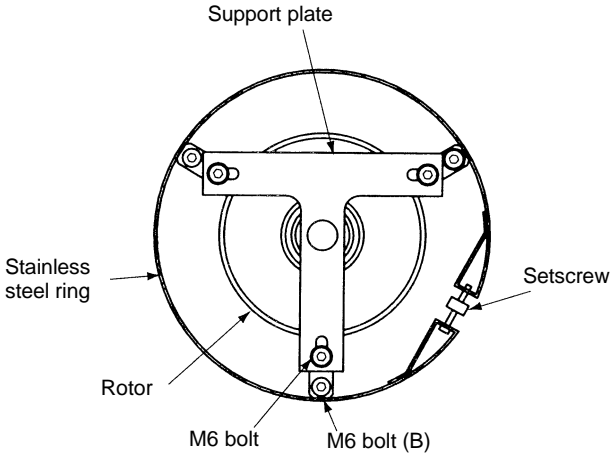
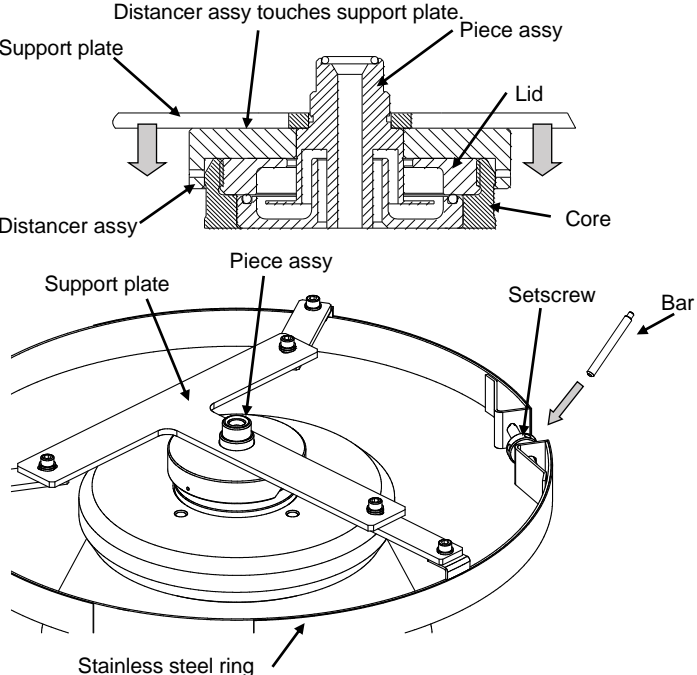

Fig. 4-2 Fixing ring

## 5. Preparation for spinning (unnecessary in case of batch rotor)

### 5.1 Seal type continuous flow rotor

Components	Procedure
 <p>Support plate</p> <p>M6 bolt</p> <p>M6 bolt (B)</p> <p>D6 spring washer</p> <p>Arm(B)</p>	<ol style="list-style-type: none"> <li>1. Use the M6 bolt to temporarily secure arm (B) to the support plate. Do not completely tighten the M6 bolt here since the position of support plate must be adjusted afterward.</li> <li>2. Put M6 bolt (B) onto the D6 spring washer as shown in the figure, and then screw the bolt into arm (B).</li> </ol>
 <p>Support plate</p> <p>Stainless steel ring</p> <p>Rotor</p> <p>M6 bolt</p> <p>M6 bolt (B)</p> <p>Setscrew</p>	<ol style="list-style-type: none"> <li>3. Set rotor in centrifuge.</li> </ol> <div style="border: 1px solid black; padding: 5px; margin: 5px 0;"> <p><b>CAUTION:</b> Avoid wrong positioning where spin shaft pins and rotor pins conflict.</p> </div> <ol style="list-style-type: none"> <li>4. Mount support plate on stainless steel ring. Insert M6 bolt (B) into mounting holes of stainless steel ring temporarily.</li> </ol>
 <p>Distancer assy touches support plate.</p> <p>Support plate</p> <p>Distancer assy</p> <p>Piece assy</p> <p>Lid</p> <p>Core</p> <p>Support plate</p> <p>Piece assy</p> <p>Setscrew</p> <p>Bar</p> <p>Stainless steel ring</p>	<ol style="list-style-type: none"> <li>5. Adjusting the height of stainless steel ring and positioning support plate horizontally <ul style="list-style-type: none"> <li>• Insert the tip of piece assembly into the hole in the center of support plate, and then place distancer assy on core.</li> <li>• Adjust the height of stainless steel ring so that support plate touches the top surface of distancers and keep positioning the support plate horizontally. The color of distancer for R18C2 is blue, that for R10C2 is red.</li> <li>• Tighten the setscrew by the provided bar.</li> </ul> </li> </ol>

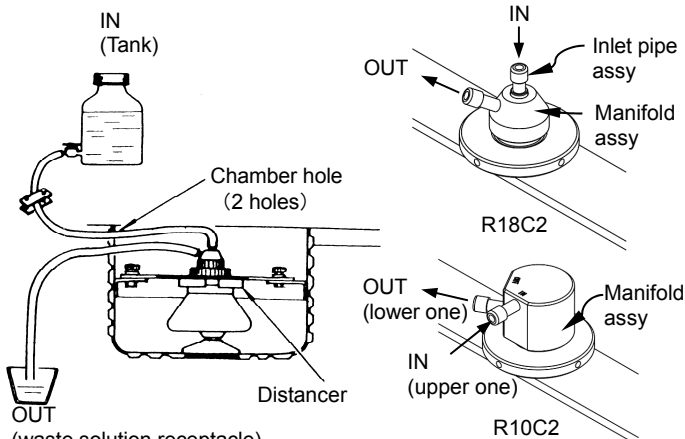
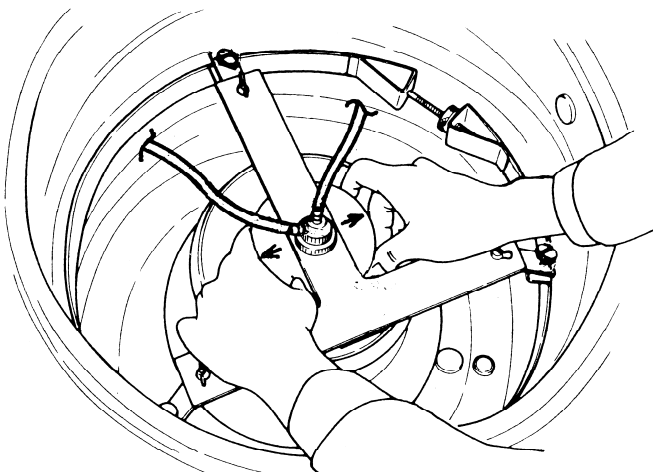
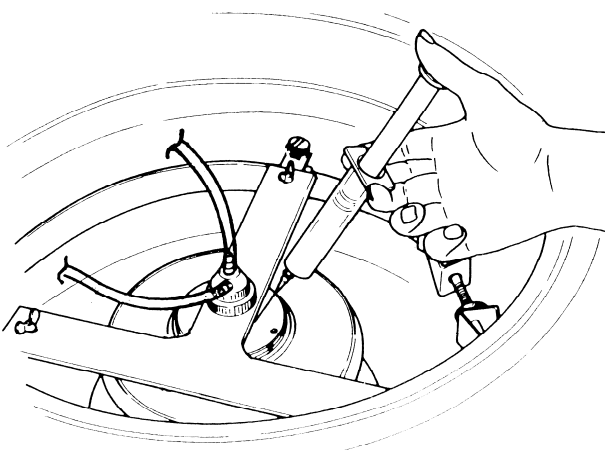

Components	Procedure
	<p>6. Aligning the center of piece assy with the center hole of support plate</p> <ul style="list-style-type: none"> <li>Adjust support plate horizontally so that gap between piece assy and support plate must be almost uniform.</li> <li>Use the provided hexagonal wrench to tighten the M6 bolts, securing the support plate in the horizontal direction.</li> <li>Raise up piece assy until piece assy touches support plate shown as the figure. Use the provided bar to tighten the lock screw in the direction of the arrow on its surface.</li> </ul> <p><b>CAUTION:</b> After each operation, make sure that none of M6 bolts and M6 bolts (B) is loose. Unless looseness is corrected, the proper position of support plate cannot be maintained, which could damage the rotor.</p>
	<p>7. With distancer placed between support plate and core, insert inlet pipe assy into hole of piece assy.</p> <p>When using R10C2 rotor, insert the O-ring (P7) (Color: Red), on which silicone grease is thinly coated, into the O-ring groove of the tip of the inlet pipe (B) assy.</p>
	<p>8. Insert the O-ring (P8) on which silicone grease is thinly coated into the O-ring groove (inside) in manifold assembly. Above work is not required in R10C2 rotor.</p>
	<p>9. With distancer placed between support plate and core, screw manifold assy on piece assy.</p> <p><b>CAUTION:</b> When screwing on, sometimes lock screw may become loose. In such case, retighten it.</p>

Components	Procedure
	<p>10. With distancer placed between support plate and core, perform piping as illustrated from the Tank to waste solution receptacle. Place the Tank on desk or bench installed at left side of centrifuge. If sample is injected using head drop, place the Tank at a point higher than the rotor. When sample need cooling, flow sample after cooling sample and the Tank.</p>
	<p>11. Remove distancer. Visually check relative position between piece assy and core (lid).</p> <ul style="list-style-type: none"> <li>◆ Gap between piece assy and lid (B) must be almost uniform.</li> </ul> <div style="border: 1px solid black; padding: 5px; margin-top: 10px;"> <p><b>⚠ WARNING:</b> Be sure to remove distancer before centrifugation, otherwise the rotor and the centrifuge might be damaged during centrifugation.</p> </div>
	<p>12. For seal operation, inject distilled water into solution holder by syringe from gap between piece assy and lid. Inject 20mL of distilled water for R18C2, 25mL for R10C2.</p>

## Installing tube holder for R18C2/R10C2 continuous flow rotors in CR30NX

Mount the tubes according to the following procedure to use a continuous flow rotor in the CR30NX centrifuge.

1. Check that there are rubber stoppers (hole plugs) and the cover on the left side of the centrifuge viewed from the front.

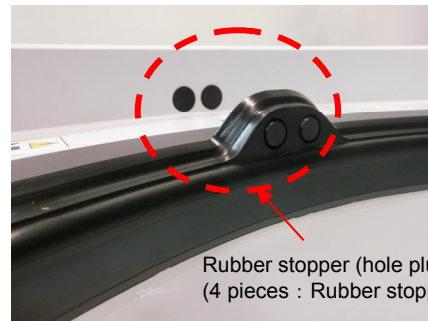
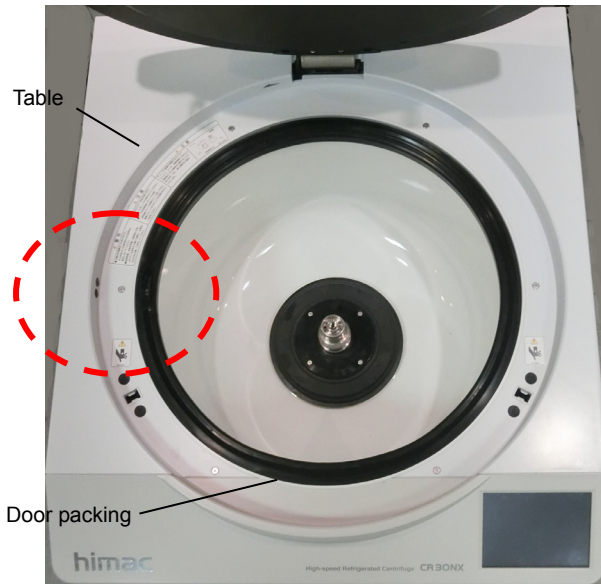

2. Remove rubber stoppers (2 pieces), which are mounted in door packing, by pressing them from the inside (shown below).  
Remove the cover and then press rubber stoppers (2 pieces), which are mounted in the table, from the outside by the bar which has flat top (shown below).

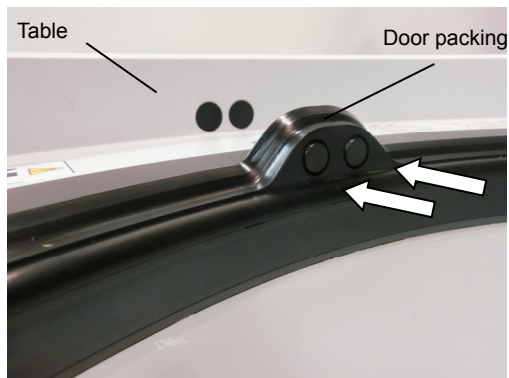

3. Connect the tubes through the holes and use a continuous flow rotor.  
Be sure to store rubber stoppers (hole plugs) that are removed from the centrifuge, because rubber stoppers (hole plugs) are required when rotors other than continuous flow rotors are used.



## 6. Determination of flow rate (unnecessary in case of batch rotor)

Separation of sample by a continuous rotor depends on the speed of revolution and flow rate. When the flow rate is constant, separation is better as the speed increases. When speed remains constant, separation degrades as the flow rate increases.

The separating conditions must be determined according to the properties of sample, e.g., the viscosity and density of solvent, the density and size of particles, sedimentation coefficient, etc. The relationship between sedimentation coefficient and flow rate under ordinary conditions will be illustrated by graphs for each rotor, with the speed of revolution taken as a parameter.

For example, to separate particles with a sedimentation coefficient of 7,000s (particle diameter of 250nm) by the R18C2 rotor at 18,000rpm, the required flow rate is 225mL/min (13.5 L/hr). When R10C2 rotor is used at 10,000rpm, the flow rate is 150mL/min (9 L/hr).

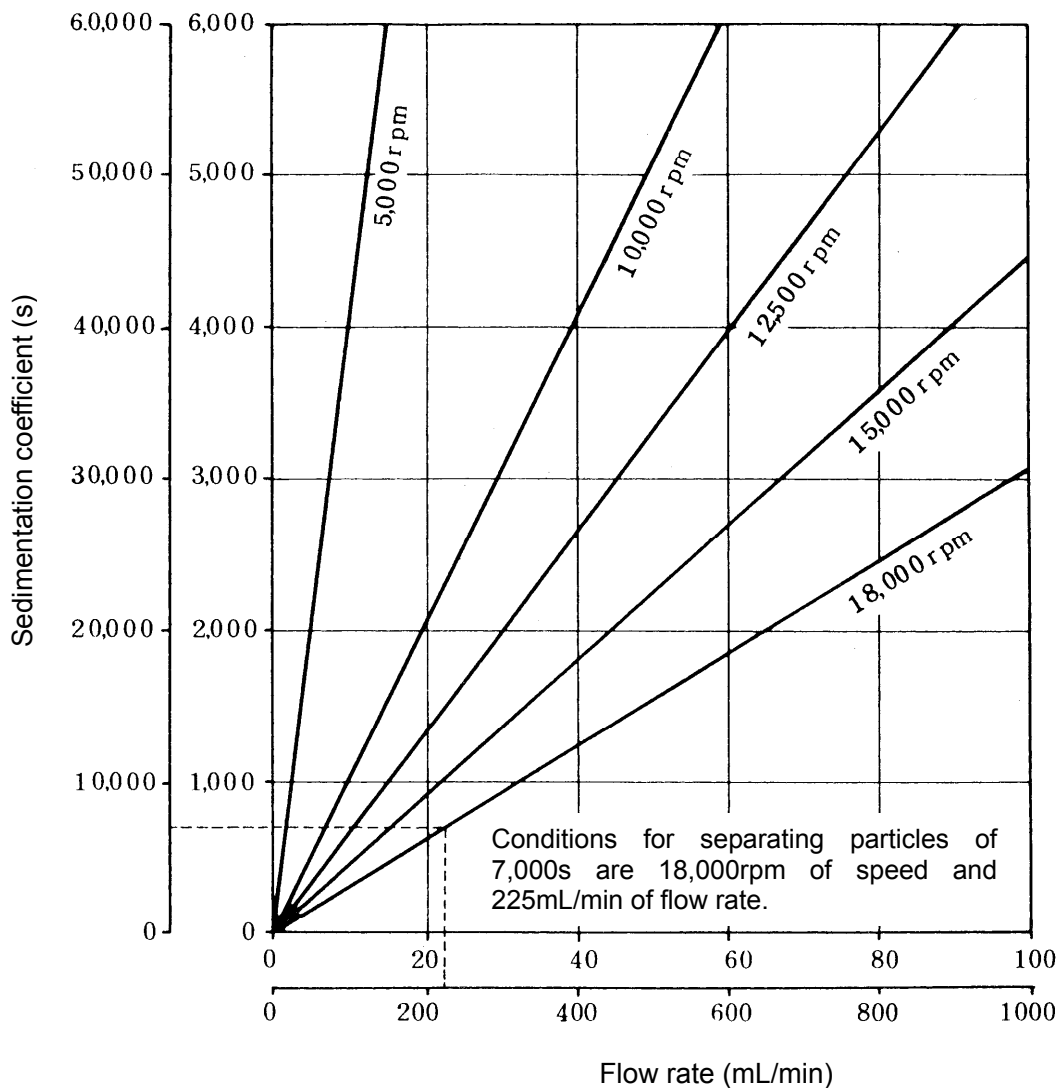

Fig.6-1 Sedimentation coefficient versus flow rate when R18C2 rotor is used

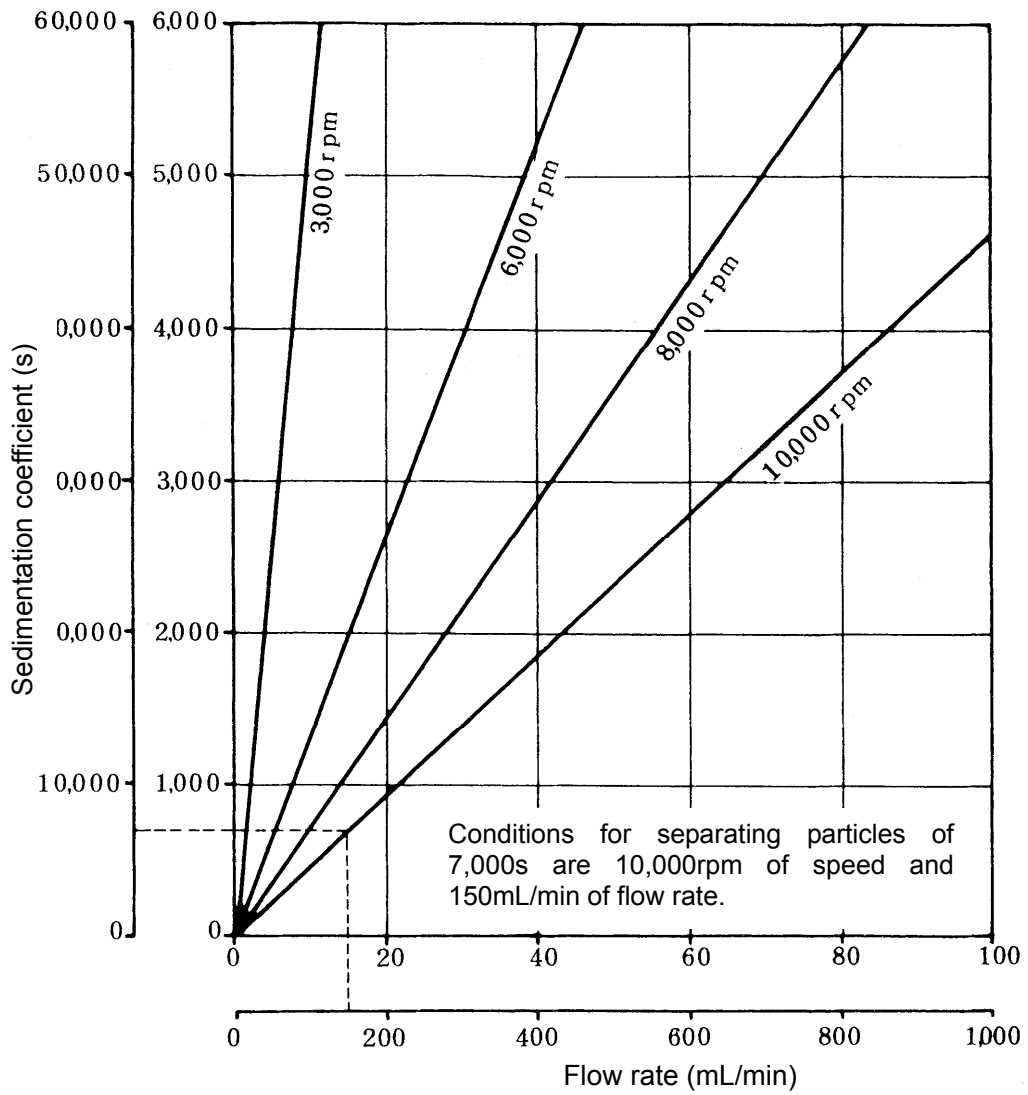

Fig.6-2 Sedimentation coefficient versus flow rate when R10C2 rotor is used

## 7. Operation

### ⚠ CAUTION:

- Check the attached chemical resistance chart, and do not use any sample inapplicable to the rotor. Otherwise the rotor may be corroded.
- Use a sample having a pH between 5 and 9. Otherwise the rotor may be discolored or corroded.
- Set the acceleration code No. to 5, 6, 7, 8, or 9 when using the seal type continuous flow rotor, because rotor swinging may become large. Failure to do so can cause the centrifuge and the rotor to be damaged.

### 7.1 Seal type continuous flow rotor

Read carefully the operation procedure in the instruction manual for the particular centrifuge.

#### Operation procedure

Operation	Automatically performed items and precautions
(1)Close the door	
(2)Turn on POWER switch	Centrifuge and freezer are energized.
(3)Set temperature to desired value.	
(4)Set time to spinning time.	
(5)Sample injection(Note1) Set speed to 3,000rpm and press start button	
(6)Open screw cock to let in sample(fill rotor completely with sample). When sample flows from waste solution port, rotor has been completely filled. Then close cock.	Sample enters rotor inside. Vibration may become quite high during this step, but it does not indicate an abnormality, and sample may be let in further. Before proceeding to high spinning, be sure to close cock.
(7)Set speed to specified value.	Rotor accelerates to high speed.
(8)As soon as specified speed is attained, open screw cock to flow sample (Note 2)(Note 3)	Sample flows at specified flow rate. The first 1-2L of sample which flows out from the waste solution port is insufficiently separated. Feed this solution back to the original tank etc. Flow rate must not exceed limit (Note2).

Note1:The above procedure shows that the rotor is filled with sample while it is revolving at 3,000rpm. You may also first fill the rotor with the sample and then accelerate it to the specified speed. At this time, be sure to inject sample more than 90%: Sample volume under 90 % will cause vibrations during acceleration.

Note2:Limit of flow rate.

The graph shows the relationships between revolving speed and flow rate limitation for seal unit.

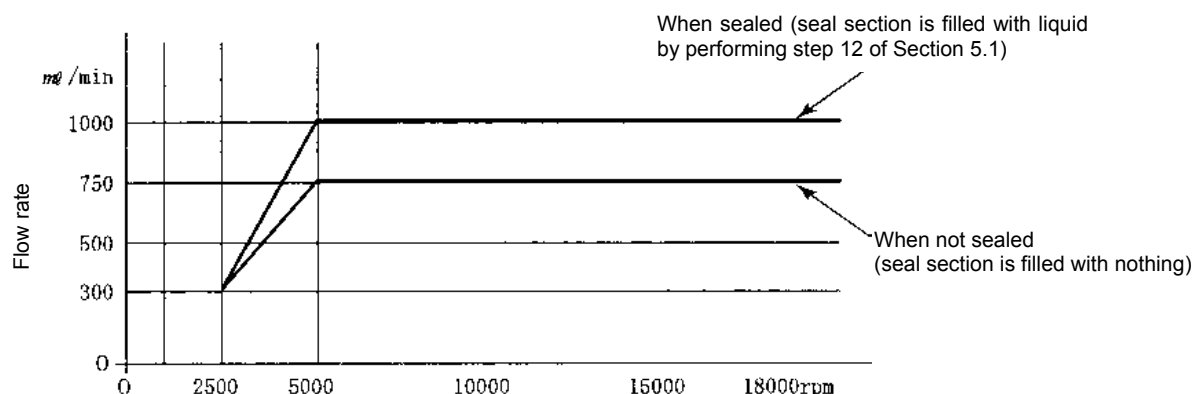

Fig.8-1 Flow Rate Limitation when Seal Unit is used with R18C2

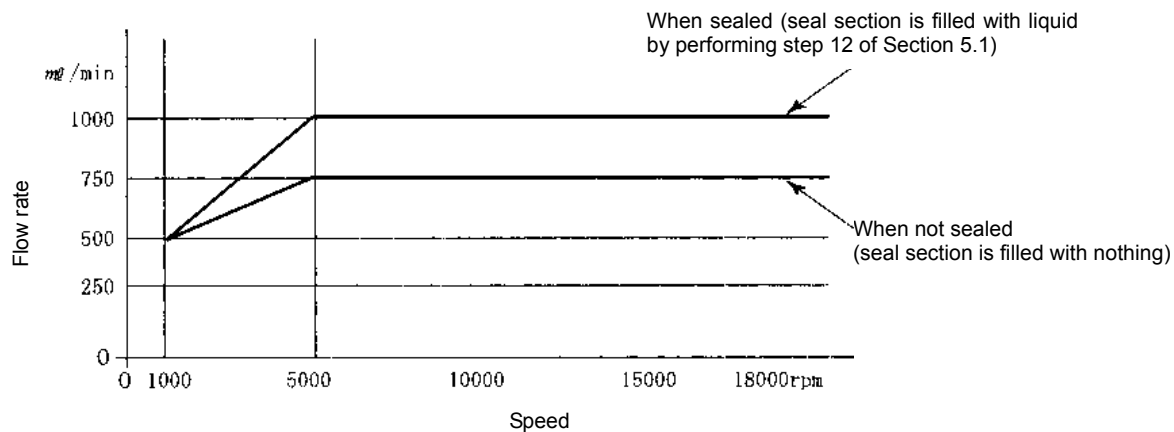

Fig.8-2 Flow Rate Limitation when Seal Unit is used with R10C2

Note3: If the viscosity of sample used with seal type continuous flow rotor is high, the sample may not flow smoothly. In this case, install pumps on both the sample injection and drain sides to facilitate the flow the sample.

## 7.2 Batch rotor

### (1) Assembly of rotor

Assemble the rotor referring to "3.3 Assembly of batch rotor".

In this case, fill the rotor body with the sample to be separated to more than 90% of its capacity before installing the blade holder assembly into the rotor body (See Note 1 in 7.1).

### (2) Preparation for spinning

The rotor has only to be put on the drive shaft of a centrifuge. No other setting is necessary.

### (3) Preparation for spinning

Rotate the rotor at high speed using the sample procedure as when rotating ordinary rotors.

#### ⚠ CAUTION:

- When using the batch rotor, cool the sample and the rotor less of the set temperature, and then tighten the rotor cover. Failure to do so can cause the rotor cover not to be removed after centrifugation, because the internal pressure of the rotor might be less of the external pressure.
- Set the acceleration code No. to 5, 6, 7, 8, or 9 when using the seal type continuous flow rotor, because rotor swinging may become large. Failure to do so can cause the centrifuge and the rotor to be damaged.

## 8. How to take out sediment

After the sample is separated, remove the rotor gently, place it on the base, disassemble the rotor by the reverse procedure to removal, and then take out the supernatant. To remove any sediment sticking to the inner wall of rotor body and the inside of center core, use plastic spoon etc., taking care not to damage the rotor.

## 9. Maintenance

### 9.1 Maintenance of rotor

After the operation, properly maintain the rotor to prevent corrosion that can cause the rotor breakage.

#### ● Normal maintenance

#### ⚠ CAUTION:

Clean the inside of the drive hole (crown hole) of the rotor and the surface of the drive shaft (crown) of the centrifuge once a month. If the drive hole or the drive shaft is stained or any foreign matter is adhered, the rotor may be improperly installed and come off during operation.

After the operation, detach both unit and rotor, and wash them with tap water or a dilute solution of neutral detergent and rinse them out with distilled water. Wipe unit and rotor with a soft cloth and dry them well. Check that unit and rotor are completely dried and then put a light coat of silicone grease (standard accessory of the centrifuge) on rotor body, cover, and center core. Store them in a dry place.

#### ⚠ CAUTION:

Use a neutral detergent having a pH between 5 and 9, otherwise the rotor and caps can be discolored or corroded.

#### ● Maintenance after use of a corrosive sample

Wash the rotor and caps with tap water immediately after the operation. Then perform the normal maintenance.

#### ● Maintenance when foreign substances are adhered to the rotor

Soak the rotor in warm water for one or two hours and wash the drive hole at the rotor bottom with a soft brush to remove foreign substances. Do not forget to remove foreign substances adhered in the drive hole at the rotor bottom, otherwise the rotor and the drive shaft may be damaged.



## 9.2 Sterilizing rotor

Sterilize this rotor in any following methods; autoclaving(120°C, 30minutes), gas sterilization method (ethylene oxide or formaldehyde), chemical sterilization method (70% ethanol, 3% hydrogen peroxide, 3% formalin), or ultraviolet rays(200-300nm) sterilization.

The rotor body, seal unit and batch unit can be autoclaved with the rotor assembled.

Sterilize the O-ring in the following method; chemical sterilization method (3% hydrogen peroxide)

 **WARNING:**

Never sterilize the rotor by boiling, otherwise they will be brittle.

 **CAUTION:**

- After autoclaving, wait until the temperature in the autoclaving chamber reduces to the room temperature, then take out the rotor.
- Take out the rotor carefully from the autoclaving chamber as it is wet and slippery.
- Do not dip the rotor in the formalin (3%) solution more than 2 hours.
- Inspect the O-ring. If the O-ring is deteriorated, it may cause the damaged O-ring during operation. Replace the O-ring if necessary.

## 9.3 Inspecting rotor

Periodically check that the rotor is free from corrosion every 100 hours use. Especially be careful of the drive hole at the rotor bottom because the rotor can be brittle if this portion is corroded. If the rotor surface is discolored, dented or cracked, the rotor is corroded. Do not use such a corroded rotor and contact an authorized sales or service representative immediately for further inspection.

## 10. Separation characteristic tables

### 10.1 R18C2

(1) When seal unit is used

Maximum speed  
18,000rpm

Total capacity  
1,000mL

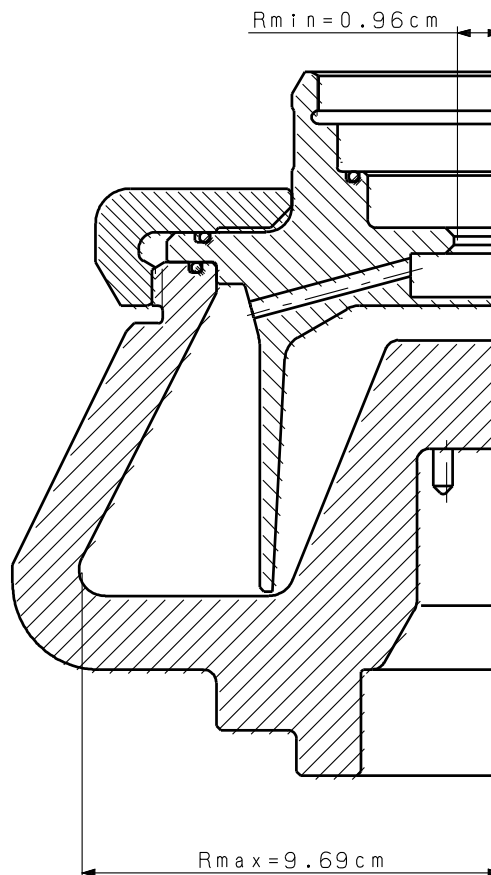

Speed (rpm)	RCF(xg)		K factor
	Rmin. (0.96cm)	Rmax. (9.69cm)	
2,000	4	433	292,217
4,000	17	1,730	73,054
6,000	39	3,900	32,469
8,000	69	6,930	18,264
10,000	107	10,800	11,689
12,000	155	15,600	8,117
14,000	210	21,200	5,964
16,000	275	27,700	4,566
18,000	348	35,100	3,608

(2) When batch unit is used  
 Maximum speed  
 18,000rpm  
 Total capacity  
 1,000mL

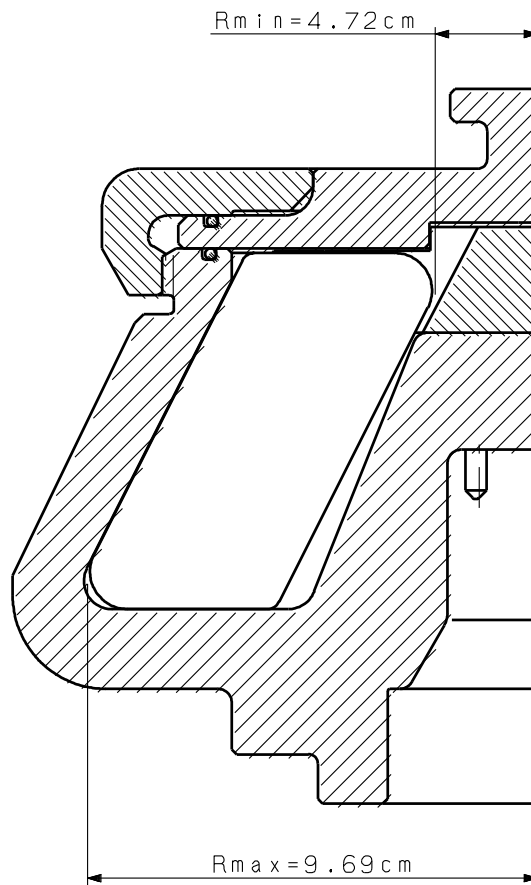

Speed (rpm)	RCF(xg)		K factor
	Rmin. (4.72cm)	Rmax. (9.69cm)	
2,000	157	433	45,549
4,000	844	1,730	11,387
6,000	1,900	3,885	5,061
8,000	3,380	6,930	2,847
10,000	5,280	10,800	1,822
12,000	7,600	15,600	1,265
14,000	10,300	21,200	930
16,000	13,500	27,700	712
18,000	17,100	35,100	562

## 10.2 R10C2

(1) When seal unit is used

Maximum speed 10,000rpm

Total capacity 3,200mL

Speed (rpm)	RCF(xg)		K factor
	Rmin. (1.05cm)	Rmax. (12.78cm)	
2,000	47	572	158,257
3,000	106	1,290	70,336
4,000	188	2,290	39,564
5,000	293	3,570	25,321
6,000	420	5,100	17,584
7,000	580	7,000	12,919
8,000	750	9,100	9,891
9,000	950	11,600	7,815
10,000	1,170	14,290	6,330

Note: The illustration is omitted because it is similar to that for R18C2.

(2) When batch unit is used

Speed (rpm)	RCF(xg)		K factor
	Rmin. (4.58cm)	Rmax. (12.78cm)	
2,000	205	572	64,928
3,000	461	1,290	28,857
4,000	820	2,290	16,232
5,000	1,280	3,570	10,389
6,000	1,840	5,100	7,214
7,000	2,510	7,000	5,300
8,000	3,300	9,100	4,058
9,000	4,200	11,600	3,206
10,000	5,100	14,290	2,597

Note: The illustration is omitted because it is similar to that for R18C2.

## 11. Decontamination

 **WARNING:**

- If the centrifuge, rotor or an accessory is contaminated by samples that are toxic or radioactive, or blood samples that are pathogenic or infectious, be sure to decontaminate the item according to good laboratory procedures and methods.
- If there is a possibility that the rotor or an accessory is contaminated by samples that might impair human health (for example, samples that are toxic or radioactive, or blood samples that are pathogenic or infectious), it is your responsibility to sterilize or decontaminate the rotor or the accessory properly before requesting repairs from an authorized sales or service representative. Note that we cannot repair the centrifuge, rotor or the accessory unless sterilization or decontamination is completed.
- It is your responsibility to sterilize and/or decontaminate the rotor or parts properly before returning them to an authorized sales or service representative. In such cases, copy the attached decontamination sheet and fill out the copied sheet, then attach it to the item to be returned. We may ask you about the treatment for the rotor or parts if the decontamination is checked and judged as insufficient by us. It is your responsibility to bear the cost of sterilization or decontamination. Note that we cannot repair or inspect the rotor or the accessory unless sterilization or decontamination is completed.

## 12. Rotor retirement







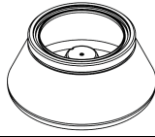
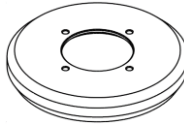

After many years of use, there will be inevitably some corrosion or stress corrosion. At some points, the combination of such damage and metal fatigue could make the rotor vulnerable to a failure.

Although a rotor may appear to be in a good condition, you should follow the rotor retirement recommendation shown below.

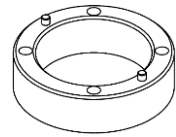
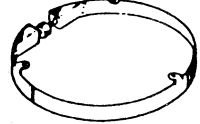
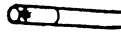

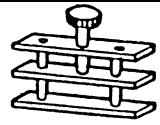







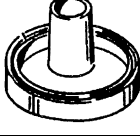

Rotor	Material	Retire After Years
Refrigerated centrifuge rotors	Aluminum alloy	15
	Stainless steel	



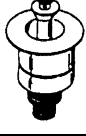







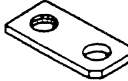

# 13. Parts List

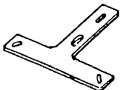
## 13.1 List of parts provided with continuous flow rotor

Name	Part No.	Model	Figure	Q'ty	Remarks
Rotor body assy	S205970	R18C2		1	
	S205977	R10C2			
Lid	S205969	R18C2		1	
	S205976	R10C2			
Handle	472138A			1	
Base assy	340633A			1	
Countersunk screw	8026443			4	
Stainless steel ring assy	S3111740A			1	
Bar	481057			1	
Spoon	472141			1	
Screw cock	466227			1	
Lubricant for screw	84810601			1	
Rotor packing	84520312	R18C2		2	G135
	84520314	R10C2		2	G175
Instruction manual	S998799			1	

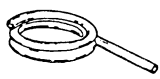
### 13.2 Components of seal unit (sold separately) for series of continuous flow rotors

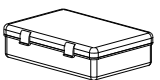
Name	Part No.	Model	Figure	Q'ty	Remarks
Core	S102782	R18C2		1	
	S102784	R10C2			
Rotor packing	84520312	R18C2		2	G135
	4836572	R10C2		2	G145
Solution holder	S408100	R18C2		1	
	481350	R10C2			
O-ring	84520311			4	G65
Lid	S408101	R18C2		1	
	481352	R10C2			
Impeller assy	S408121B	R18C2		1	
	481375B	R10C2			
Piece assy	S304946B	R18C2		1	
	341541B	R10C2			
O-ring	84520303			3	P14 One ring is already installed in piece assembly.
O-ring	84520301			3	P6 One ring is already installed in piece assembly.
Inlet pipe assy	341543A	R18C2		1	
	S413934A	R10C2			
Manifold assy	481360A	R18C2		1	
	S413935A	R10C2			
O-ring	84520302	R18C2		3	P8 One ring is already installed in manifold assembly.
	84522301	R10C2		3	P7(Color: Red) One ring is already installed in manifold assembly.

Name	Part No.	Model	Figure	Q'ty	Remarks
Arm (B)	S4006682			3	
M6 bolt	84553201			3	
M6 bolt (B)	488037			3	
Spring washer	80112078			3	
Hexagon wrench	S413606			1	
Support plate	S305532			1	
Lock screw assy	S403915B			1	
Bar	S401166			1	
Distancer assy	341545B	R18C2		1	
	341545A	R10C2			
Handle (2)	481368			1	
Silicone tube	84710306			1	OD <sup>*1</sup> : 10 mm ID <sup>*2</sup> : 6 mm L <sup>*3</sup> : 3000 mm
Tank	481370			1	5L
Tool box	S205074			1	
Screw	488037			3	
Packing list	S998731			1	





\*1: Outer diameter

\*2: Inner diameter

\*3: Length

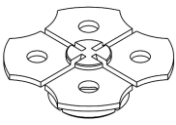

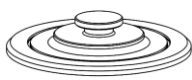
13.3 Components of batch unit (sold separately) for series of continuous flow rotors

Name	Part No.	Model	Figure	Q'ty	Remarks
Blade holder assy	R18C2	481378		1	
	R10C2	481384			
Blade	R18C2	481380		4	
	R10C2	481385			
Cover assy	R18C2	S413917		1	
	R10C2	S413932			
Rotor packing	R18C2	84520312		2	G135
	R10C2	4836572			G145
Packing list		S998725		1	

---

# MEMO

---

---

# MEMO

---

---

**Eppendorf Himac Technologies Co., Ltd.**

1060, Takeda, Hitachinaka City  
Ibaraki Pref., 312-8502 Japan

URL: <https://www.himac-science.com>