

# Independent ULT Freezer Checks – Third-Party Test Methods

Jan Bebermeier  
Eppendorf SE

Eppendorf is committed to accountability, consistency, and transparency in providing performance data of our ULT freezers. Our goal is to provide our customers with reliable data about our instruments to enable a decision based on trust; that trust is based on independence verification. In this white paper, we describe how the published Eppendorf performance data are generated by an external testing agency utilized by Eppendorf. In addition, multiple CryoCube® ULT freezer models are ACT® certified by My Green Lab® for their sustainability and have received the ENERGY STAR® label for their low energy consumption.

As with other technical equipment, many buyers like to compare the performance of ULT freezers before deciding to purchase one model over another. This approach is logical: ULT freezers are an investment that is meant to last for the next 10-12 years or longer. The performance over time could have significant impact on overall cost of ownership for the freezer. In general, there is a major point of interest for the user: performance of the freezer.

Did you ever calculate the value within your freezer? All the hours, days, weeks, and months spent on your samples? More than 50,000 samples fit into large, standard ULTs. The value of every single sample differs – from simple buffers to high-value cell extracts, expensive enzymes, or very rare sample material. Assuming an average value of 10 Euro or Dollar per vial, the total value already reaches 500,000 Euro or Dollar. When predominantly storing high-value samples which are a result of months of work – you reach a value in your freezer far beyond half a million Euro or Dollar.

Your new ULT freezer is not limited to being a storage room for samples. This instrument is your assurance for long-term scientific success, it guards the results of your work. Therefore, performance and reliable information about performance matters.

Sustainability and ULT freezers may seem like an opposing combination: even the latest and most environmentally-friendly and energy-efficient ULTs still require a significant amount of power to maintain extremely low temperatures of -80 °C 24/7. With today's high energy costs and increased focus on environmental consciousness, energy conservation has

become even more important in the lab. But how much energy is needed for the ULT freezer per day at the dedicated -80 °C and in daily, routine operation? How much energy savings and improved efficiency of the cooling system can be relied upon? There is a negative causal interaction between power savings and temperature performance: at some time point of further energy savings, you start to pay the price by having slower pulldown times, slower recovery time after opening, and less exact temperature performance. In other words, from that point of energy savings onwards, you put your samples at risk.

As a freezer supplier, we want to provide you with instruments where this turning point is optimized: Using as little power as possible whilst maintaining all performance data in an area where your samples are safe.



Figure 1: Performance measurements of Eppendorf ULT freezers

The safety of the stored, high-value samples is key. What is the temperature uniformity within the freezer? How efficient is the instrument? How long does it take for the unit to pull down to -80 °C? How long does it take to recover back to real -80 °C after a door opening of, e.g., 60 seconds? Does it make sense to change the setpoint from -80 °C down to -70 °C? The comparison of ULT freezers is challenging, as there are no global standardized testing conditions in the field of freezers. Fuel consumption of cars is nowadays based on the WLTP (world harmonized light-duty vehicles test procedure), washing machines or similar household devices in the EU have the color code based ranking, but the testing of ULT freezers (unlike most other lab instruments) is not defined.

Every supplier of ULT freezers has their own method of testing. Many published data do not include a description of the dedicated test conditions. These tests are always different, and there is no right or wrong in the results as long as the testing conditions are reliable, documented, and published. The performance measurements of power consumption, temperature uniformity, pull-down times, or door-open-recovery time (DOR) depend on environmental conditions like room temperature, ventilation, humidity, freezer load, the used measurement instruments, as well as the position of probes during the check. Like in science, the results must be analyzed and discussed (see also Eppendorf White Paper 058). As a result, any comparison between different models requires a time-consuming study of the different published data sets. As a potential buyer, you need to take into account different test methods. Unlike a pipette or centrifuge, a large ULT freezer cannot be easily sent for testing in your own lab due to size, weight, and logistics.

At Eppendorf, we respect external test procedures and external independent test results of our ULT freezers. This includes test results which might differ from our published data, worse as well as better data. As already stated, there is no right or wrong data set. Based on discussions with the My Green Lab organization, who manages the ACT label for sustainable impact of lab equipment, we decided to provide more background information about our testing procedures for Eppendorf ULT freezers.

### Testing procedure

The technical performance of a new ULT freezer needs to be optimized in the R&D process. Afterwards, these data need to be validated. During the development phase of a new Eppendorf freezer, on-going checks are performed in-house, by standard. These numerous tests are performed in dedicated environmental chambers in the R&D departments to understand and optimize the performance of our freezer prototypes. Changes in sealings, wall insulation, or the location of the cooling coils all have an impact on the performance.

For the final tests, we at Eppendorf believe in an independent, external counter control. To fulfill this request, we

co-operate with an external European testing body with highly trained engineers. As there can be slight performance differences between single units, three units of ULT freezers of the same kind (serial production level) are sent to the testing body. The external testing of these instruments is performed with defined and standardized conditions, following a dedicated standard operating procedure (SOP). This means, for example, specific room temperature, controlled humidity, validated & certificated testing instruments, and exact positioning of temperature probes. All conditions and results are documented and signed. The resulting external test data, like power consumption, temperature performance, and pull-down times of our new freezer, are then averaged based on the data of the three units involved. These three units are the origin for all Eppendorf-published technical data about the specific freezer type. In other words, the technical performance data of Eppendorf freezers published are measured externally by an independent, third party.

#### Test conditions

General	Eppendorf test body
Number of units	3x (serial production)
Power supply	Power supply voltage: 230 V (+/- 1%) Frequency: 50 Hz (+/- 0.2%) Other voltages are tested equally.  Power supply voltage is checked before the ULT is plugged into the socket and checked afterwards as well, documented and signed.
Test equipment	> Test equipment is specified and listed by name > Test equipment is documented per test by serial number, calibration date, signature
Test conditions (ambient)	
Humidity	40% (+/- 10%)
Room temperature	Average ambient temperature: 20 °C (+/- 1 °C) (68 °F; +/- 1.8 °F)
Air current	Closed environmental test chamber

The definition of the test equipment is key for exact measurements. It is important to document the equipment used and to ensure regular checks and certification of the test equipment.

The voltage includes a variance of up to +/-1%. Similar to this, the power frequency has a limited variance of +/-0.2%. For different voltages, the Eppendorf test body performs the test with the dedicated voltage supply the ULT freezer may use (e.g. 100, 115, 208, and 230 V) in separate runs where possible. As the 100, 115, and 208 V require a technical voltage transformation of the original 230 V at the test house, the final voltage only symbolizes regional voltage. Details of the local voltage supply, e.g., 115 V, like specific variances can not be mimicked 100% as the voltage converter from 230 V to 115 V is controlled by electronic filters. We assume that this artificial voltage has very limited impact on the real performance data of the freezer.



**Figure 2:** Temperature probe positioned within freezer cabinet

Humidity around the freezer has a midterm influence on ice-build-up but should have a limited impact in a 24h measurement. Documentation of humidity is given in our testing. The environmental temperature is set to 20 °C +/- 1 °C (68 °F +/- 1.8 °F). The 20 °C temperature is similar to the ambient temperature used by other suppliers like Thermo Scientific® and adapted to the recommended temperature for freezer locations.

The Eppendorf test body uses encapsulated PT100 temperature probe heads which have a similar encapsulation as a dry bulb. The test is performed in a closed environmental test chamber where no air current is expected.

The performance test is at least 24 hours; when a longer time is measured, the value is calculated per 24 h. Test runs are done at -70 °C, -80 °C, and -85 °C with dedicated adaption times in between.

### Test setup of ULT freezer

The basic setup is to test the instrument in typical conditions. The instrument is set up in accordance with the instructions supplied with the instrument. The serial production standard of the instrument provides test units which are similar to the situation in the user lab. The shelves are installed as given by standard, gaskets are set by standard. Any operational mode which may result in better performance but is not used during normal operation is not allowed. The test is based on standard operating conditions of the instrument. The units are unpacked (serial level packaging) and adapted in the environmental chamber for at least 2 h before starting the first measurements. The instrument installation is done according to instructions in the Eppendorf operating manual. By definition, this is 15 cm (6 in) from the back wall and at least 15 cm (6 in) distance to lateral objects. The distance is a commonly recommended distance by many suppliers.

### Positioning of the ambient temperature sensor in the test room

The ambient probe head (PTD100) is located centralized with 100 cm distance from the closed central freezer front and at 100 cm height. The actual distance is to be documented. The procedure does not differentiate between upright and chest freezers.

### Positioning of the temperature sensors within the ULT freezer

The PTD100 for the temperature measurement within the instrument have a polymer-structured cover. This cover shall dampen the micro temperature variations caused by air movements within the cabinet by using an inertness factor. The probes are positioned in uncovered dedicated holders. The probe cables are routed into the cabinet using the access port.

For the upright ULT, 15x probes are used. This means by standard, there are 5x probes per compartment/plane.

The standard measurement layout is based on 3-compartment freezers. Freezers with more compartments are equipped with the same set and position of probes.

The positioning of the temperature probes is 75 mm (3 in) +/- 2 mm (0.08 in) away from the freezer wall. Probes in the upper most compartment are located 38 mm (1.5 in) below the ceiling. Probes in the lowest compartment are located 25 mm (1.0 in) above the bottom shelf. Cornered probes as well as centered probes take into account potential differences in the chamber environment. Critical for comparing different freezers is the position of probes in respect to cooling coils behind the inner chamber wall. The distance between the cooling coil and the temperature probe may have an influence on the correctness of the value. Exact correlations are missing and the method does not take this potential factor into account.

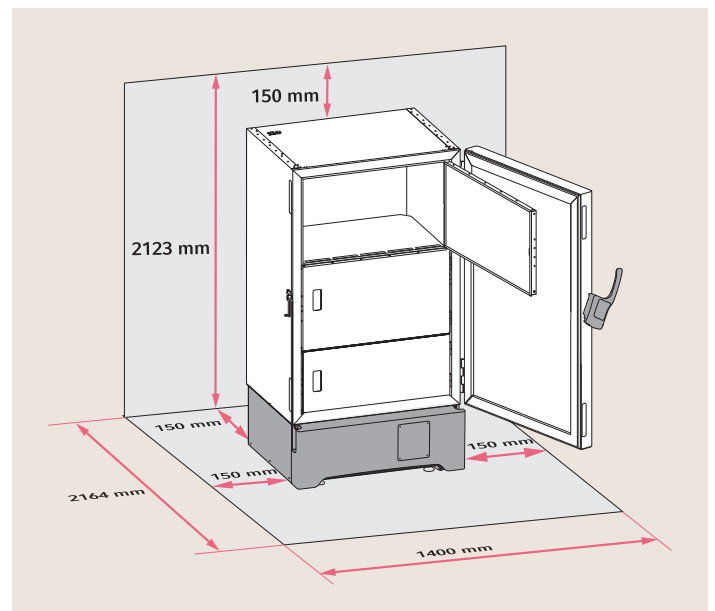

**Figure 3:** Recommended distances for installation of Eppendorf ULT freezer

The built-in temperature probe detects the actual temperature within the freezer. Comparing this measured value with the set value, the instrument decides if an up or down adjustment is needed. The positioning of this probe is crucial for accurate freezer uniformity and optimized operation. Improper placement by the manufacturer can lead to inefficient cycling and a gap between your setpoint and the actual temperature inside the freezer.

The lowest compartment is the coldest spot in the freezer, as cold air falls down. Logically, this compartment is the one where the set temperatures is reached the fastest. As a result, the unit with the built-in probe in the lowest compartment may stop cycling despite the temperature of 2/3 of the freezer volume still being significantly different than the temperature setpoint. This saves time and energy at the cost of putting samples at risk.

Eppendorf positions the probe in the middle of the ULT chamber to receive an average value of the temperature distribution. This helps prevent inaccuracy and inefficiency; it grants peace of mind knowing your setpoint is being maintained accurately.

**Temperature documentation**

The temperatures are to be documented in a pre-defined interval of 30 s timeframes of measurement points. The temperature setpoints are defined as -70 °C, -80 °C, and -85 °C. The measurement is based on the setpoint of the freezer (display). The temperature is recorded by each TMD in the cabinet.

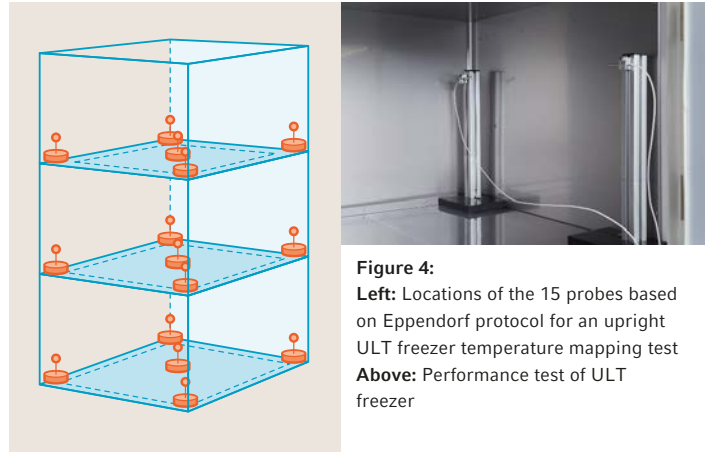

**Figure 4:**  
**Left:** Locations of the 15 probes based on Eppendorf protocol for an upright ULT freezer temperature mapping test  
**Above:** Performance test of ULT freezer

**Pull-Down time**

The pull-down time is defined as time period (T0 to T1) to cool down the inner chamber from room temperature (+20 °C) to setpoint of, e.g., -85 °C. The initial pull down depends on the unit, but is typically measured until the unit(s) reach(es) the setpoint at a stable level.

The pull-down time is relevant for the initial pull-down of the instrument and for any pull-down after defrosting. Additionally, the pull-down time is a strong indicator about the cooling performance as pull-down of the temperature is required after every door opening. That means, the shorter the general pull-down time from room temperature to the -80 °C setpoint, the faster the instrument can recover back to the (-80 °C) setpoint after door openings (see also Door Opening Recovery test). This results in a higher level of safety for your frozen samples in the freezer.

Table 2 shows the dependency of the freezer volume to different times to reach the setpoints. The goal of our freezer development is a fast and efficient pull-down performance for immediate availability of the instrument. That means, even a backup freezer does not need to run 24/7 as it is ready-to-use within 4 h. This concept saves energy and costs, combined with high-performance cold storage.

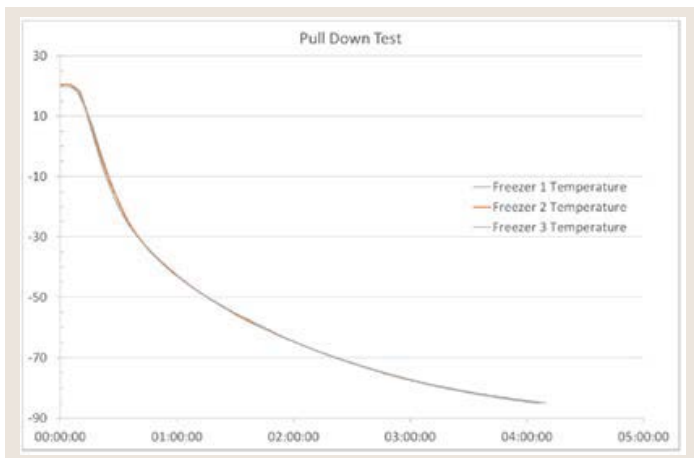

**Figure 5:** Pull down test for CryoCube F440h (230 V) with 3 independent units from ambient room temperature down to -85 °C

Freezer	-70 °C	-80 °C
CryoCube F440h	2 h 25 min	3 h 20 min
CryoCube F570h	2 h 30 min	3 h 30 min
CryoCube F740hi	2 h 45 min	4 h 10 min

**Table 2:** Pull down times of different Eppendorf CryoCube ULT freezers based on 3 independent units each (230 V)

### Door Opening Recovery test

The Door Opening Recovery test (DOR) is one of the major aspects when validating the ULT freezer. How often do you open the ULT freezer door per day? For how long? It is best practice to always open and close the freezer as quickly as possible when storing new samples or attempting to locate a sample which is stored out of sight. However, this takes time. The more time it takes, the more the temperature of both the cabinet and your frozen samples increases. The longer the door remains open, the longer it takes for the freezer to regain the set temperature. 30 to 60 seconds is a realistic time frame to add a new sample or remove a stored one.

The better you know the position of your sample within the ULT freezer, the more time you will save. A smart software-based inventory system may help you.

The Door Open Recovery time (DOR) is the time required for the freezer to return to the setpoint, e.g., -80 °C, after opening and closing the door. When the starting (set) point is -80 °C, measuring the recovery time back to -70 or -75 °C does not make sense as the last degrees before -80 °C are the time-critical part. Check carefully when reading recovery times without dedicated information about the “back to temperature”.

For the Door Open Recovery tests, the main door is opened to an angle of 90 ° and the inner center door is opened to a 90 ° angle. The opening is done for a specific timeframe of 15 s, 30 s, 60 s, or 120 s. See typical data in table 3. The dedicated openings are separated from each other by 60 min to guarantee a constant starting temperature. After the opening, the time is measured until the freezer returns to the set temperature, e.g., -80 °C.

The recovery rate depends on the performance of the cooling system. Power savings in the design of the cooling system can result in a loss of performance, e.g., when recovering the temperature, as power usage and performance interact directly. At a certain point, power savings deliver diminishing returns as you begin to have performance deficiencies due to slower pulldown times, slower recovery time after opening, and less exact temperature performance. In short, after the point of optimized energy savings, you put your thousands of samples at risk. A freezer that uses minimal energy is useless if it does not keep your samples safe.

Freezer	15 sec	30 sec	60 sec
CryoCube F440h (230 V/50 Hz)	13 min	17 min	27 min
CryoCube F570h (230 V/50 Hz)	14 min	19 min	27 min
CryoCube F740hi (230 V/50 Hz)	18 min	25 min	27 min

**Table 3:** Recovery rate of selected Eppendorf ULT freezers (230 V) at -80 °C set point and return to -80 °C, different opening times



**Figure 6:** Every door opening of an ULT freezer results in a warm-up of the inner compartment which requires a fast pull-down back to the setpoint

In Summer 2021, Stirling Ultracold® published a White Paper indicating the very good recovery rates of their 780 L unit after door opening of 15 sec for warmer run temperatures like -40 °C or -50 °C. This is true and remarkable. Still, we see the major impact for the users at the real ULT freezer temperature range of -70 °C and -80 °C.

The comparison in table 4 clearly shows the advantages of the powerful two-stage compressor-based cooling system like the Eppendorf CryoCube F740hi where door openings can be handled by the instrument in below 20 min when opening the doors for 15 sec.

15 sec opening	Stirling® SU780XLE	Eppendorf CryoCube® F740hi
-40 °C	18 min	-
-50 °C	21 min	-
-70 °C	26 min	12 min
-80 °C	35 min	18 min

**Table 4:** Recovery rate of Stirling Ultracold SU780xx (115 V) (published as a White Paper by Stirling Ultracold) and Eppendorf ULT freezers (230 V) at specific set-points and reaching back the same setpoint, the compared opening time is 15 sec

### Chamber design

The impact of opening the inner door may differ between different freezer models. Depending on the number of inner doors, the size of each door may differ. Typically, a larger number of inner doors means each door is smaller in size. Therefore, opening a freezer with just two inner doors exposes 50% of the inner freezer chamber whereas a freezer with three inner doors exposes only 33%. But these 33% are half way in the lower (colder) 50% area of the body whereas the upper 50% of the two-door-system are in the warmer 50% of the body.

Although the upper door opening of the two-door system results in a bigger exposure due to its bigger surface, the effect is less towards the loss of cold air and the impact of the counter-cooling by the cooling system after closing as more cold stays in the unit. Another aspect of the surface area that can impact results is the difference between two different freezer chamber designs. The majority of ULT freezers provide a 4-box-deep rack system, while several models are equipped with 5-box-deep rack systems. When providing the same volume (i.e. the same total number of freezer boxes), the 5-box-deep freezer has a smaller opening compared to the 4-box-deep system. This can lead to a result that is only semi-comparable due to significantly different opening surfaces.

### Energy Consumption

For its power consumption test, the doors are closed for 24 h as a stable, non-influenced running state is the most reliable one from our perspective. Before the 24 h test, the unit is stabilized for an additional 4 hours.

The power consumption is measured for 24 h and also published as value/day. Be aware that some suppliers publish power consumption values per hour.

### Summary

As freezer supplier, we want to provide you with instruments of optimal performance: consuming as little power as possible whilst still maintaining all performance data in an area where your samples are safe.

The technical performance of a new ULT freezer is optimized in the R&D procedure. Finally, these data need to be validated. For the final tests, we at Eppendorf believe in an independent, external counter control. To fulfill this request, we co-operate with an external testing body. To reduce the impact of inter-instrument variations, three units of ULT freezers of the same kind (serial production level) are measured by the testing body. The external testing of these instruments is performed with a dedicated standard operating procedure (SOP).

The resulting external test data are averaged and being used as origin for all Eppendorf-published technical data about the specific freezer type. Technical performance data of Eppendorf freezers published are measured externally by an independent third party.

## About Eppendorf

Eppendorf is a leading life science company that develops and sells instruments, consumables, and services for liquid-, sample-, and cell handling in laboratories worldwide. Its product range includes pipettes and automated pipetting systems, dispensers, centrifuges, mixers, spectrometers, and DNA amplification equipment as well as ultra-low temperature freezers, fermentors, bioreactors, CO<sub>2</sub> incubators, shakers, and cell manipulation systems. Consumables such as pipette tips, test tubes, microtiter plates, and single-use bioreactor Vessels complement the range of highest-quality premium products.

Eppendorf was founded in Hamburg, Germany in 1945 and has more than 5,000 employees worldwide. The company has subsidiaries in 33 countries and is represented in all other markets by distributors.

**Your local distributor: [www.eppendorf.com/contact](http://www.eppendorf.com/contact)**

Eppendorf SE · Barkhausenweg 1 · 22339 Hamburg · Germany  
[eppendorf@eppendorf.com](mailto:eppendorf@eppendorf.com) · [www.eppendorf.com](http://www.eppendorf.com)

[www.eppendorf.com](http://www.eppendorf.com)